

**Permanent Magnet (7 - 1)**

Permanent Magnet is a metal whose chemical composition is an iron oxide .

**Magnet properties**

- 1) It has two poles north (N) and south (S) .
- 2) Opposite magnetic poles attract , and like magnetic poles repel .
- 3) If it is suspended freely, it takes a direction north - south .
- 4) If it is cut , each piece consists of two poles .  
(No magnetic monopole exists)
- 5) It attracts iron , nickel , and cobalt .

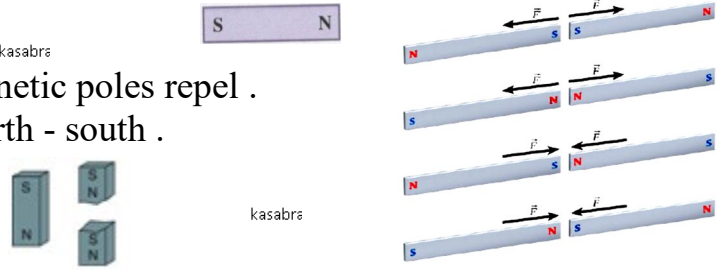

**The Magnetic field ( $\vec{B}$ )**

The unit is : Tesla (T)

There is another unit called Gauss where :  $(1G = 10^{-4}T)$

The direction of the field at a point :  
is the direction of the North Pole of the compass needle .



**Properties of magnetic field lines**

- 1) Closer spacing between the field lines indicates to higher field strength .
- 2) The magnetic field vector is a tangent to the magnetic field lines .
- 3) Magnetic field lines form a closed loop because no magnetic monopole exists .  
It looks like it is directing from the North Pole to the South outside the magnet and from the south to the north inside the magnet .

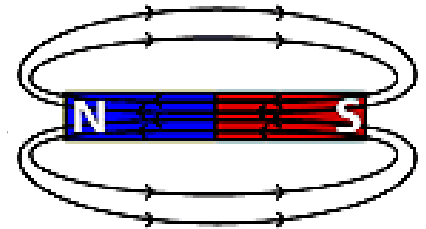

The direction out of the page usually means (+ z) axis and it is represented by the symbol  $\odot$  .  
The direction into the page usually means (- z) axis and it is represented by the symbol  $\otimes$  .

في درس (7-1) فقرة Earth's magnetic field ص 171 و ص 172 (محدوفة)

**Magnetic Force (7 - 2)**

**1) Magnetic force on a moving charged particle**

$$\vec{F} = q\vec{v} \times \vec{B}$$

$$F = |q|vB \sin \theta$$

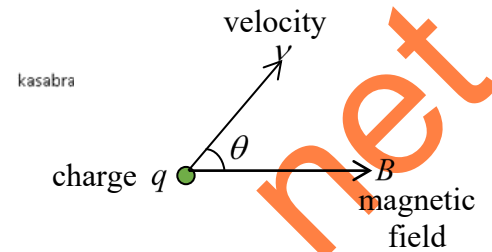

If the particle moves parallel or antiparallel to the field,  $(\theta = 0 \text{ or } 180^\circ)$  then :

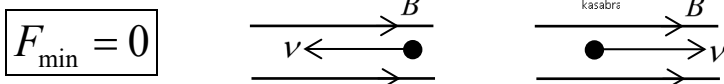

If the particle moves vertically on the field,  $(\theta = 90^\circ)$  then :

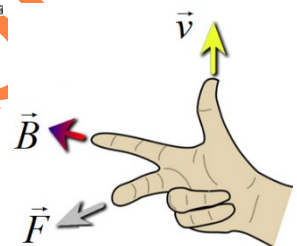
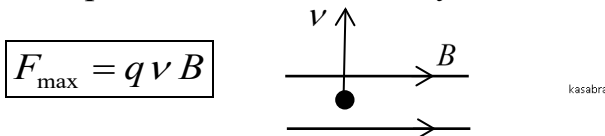

Direction of Force determine by (right-hand rule 1) as shown .

OR : Thumb with velocity , fingers with field

The direction out of the right hand is the direction of the force on the positive charge .

(if the charge is negative, we take the direction out of the back of right hand)

Direction of ( $\vec{F}$ ) is always perpendicular to both ( $\vec{B}$ ) and ( $\vec{v}$ )

Q1) Determine the direction of magnetic force in the following cases .

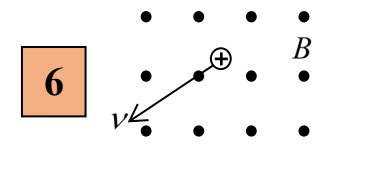
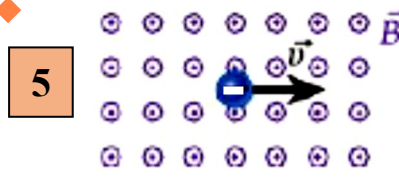
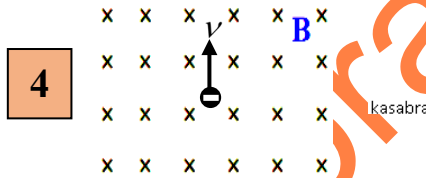
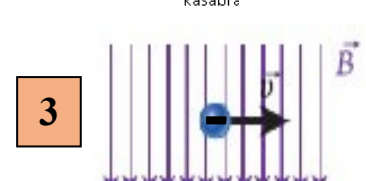
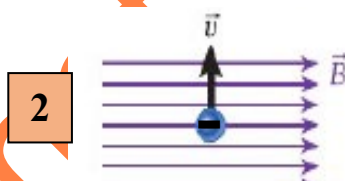
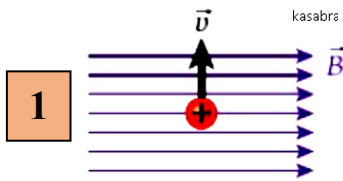

Q2) A Proton is moving with a speed of  $(4.0 \times 10^5 \text{ m/s})$  in the positive y-direction enters a uniform magnetic field of  $(0.4 \text{ T})$  pointed in the negative x-direction , Calculate the magnitude of the force on the proton and determine its direction .

Q3) A particle with a charge of  $(-20 \mu\text{C})$  moves along the negative x-axis with a speed of  $(50 \text{ m/s})$ . It enters a magnetic field given by  $(\vec{B} = 0.3 \hat{x} + 0.7 \hat{z})$  in teslas . Determine the magnitude and the direction of the magnetic force acting on the particle .

Q4) A particle with a charge of  $(-2e)$  moves with a speed of  $(1.0 \times 10^5 \text{ m/s})$  in a uniform magnetic field , Calculate the minimum magnetic field needed to affect on the particle with a force of magnitude  $(3.0 \times 10^{-18} \text{ N})$  .

Q5) Suppose in a cathode ray tube there is an electron accelerates through a potential difference of  $(111 \text{ V})$  and then it enters a uniform magnetic field of  $(3.4 \times 10^{-4} \text{ T})$  as shown in the figure , by considering  $(m_e = 9.1 \times 10^{-31} \text{ Kg})$  :

1) Calculate the magnitude and the direction of the magnetic force on the particle as soon as it enters the field .

2) Calculate the magnitude of the electron's acceleration when it is moving through the magnetic field .

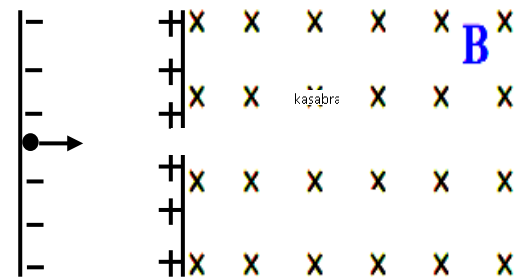

Q6) A negatively charged particle moves with a speed of  $(300 \text{ m/s})$  in the positive y-direction in a region containing two perpendicularly uniform electric and magnetic fields . If the electric field is  $(120 \text{ V/m})$  in the positive x-direction as in the figure , calculate the magnetic field required to keep the particle moving in a straight line at constant speed and determine its direction .

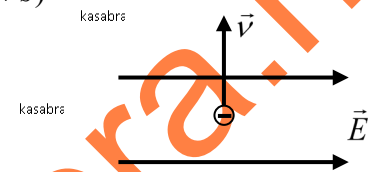

Q7) A Proton is moving with a speed of  $(200 \text{ m/s})$  in a region containing a uniform electric field  $(1000 \text{ V/m})$  and a uniform magnetic field  $(1.2 \text{ T})$  as shown in the figure where :

1) Calculate the acceleration of the proton as soon as it enters the two fields and determine its direction .  $(m_p = 1.67 \times 10^{-27} \text{ Kg})$

2) Calculate the acceleration of the proton if the direction of the proton's velocity is reversed .

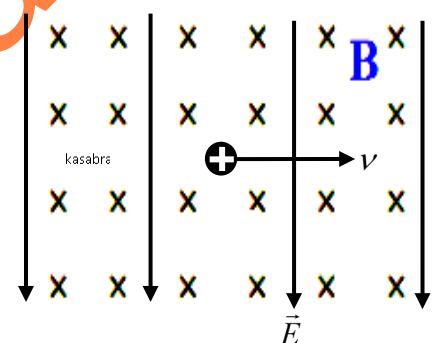

The work of the magnetic force on the moving particle is equal to zero, Explain ?  
Because the magnetic force is always perpendicular to the velocity and thus it is :

$$W = F d \cos 90^\circ = 0$$

The magnetic field does not affect the kinetic energy and the magnitude of velocity .

$$W = 0 \Rightarrow \Delta K = 0 \Rightarrow K \text{ constant}$$

The magnetic field only changes the direction of velocity .

Q8) Choose the correct answer in each of the following

1) Which of the following units is equivalent to the magnetic field unit (Tesla) ?

- a)  $N \cdot A^{-1} \cdot m^{-1}$       b)  $N \cdot A \cdot m^{-1}$       c)  $N \cdot m \cdot C^{-1}$       d)  $N \cdot m \cdot A^{-1}$

2) Which of the following units is equivalent to  $(Kg \cdot C^{-1} \cdot S^{-1})$  ?

- a) Volt      b) Newton      c) Ampere      d) Tesla

3) A proton entered a uniform magnetic field pointing to the right and the magnetic force acts on it was in direction out of the page, in which direction the proton entered the field ?

- a) downward      b) left      c) upward      d) right

4) A proton is moving in a uniform magnetic field, as shown in the figure. What is the direction of the magnetic force on the proton ?

- a) downward      b) left  
c) upward      d) right

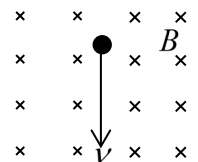

5) An electron is moving with a velocity of  $(7.4 \times 10^5 \text{ m/s})$  perpendicular to a magnetic field, the electron is affected by a force of magnitude  $(2 \times 10^{-13} \text{ N})$ , Calculate the magnitude of the magnetic field ?

- a)  $8.2 \times 10^{-15} \text{ T}$       b)  $0.31 \text{ T}$       c)  $1.7 \text{ T}$       d)  $1.7 \times 10^{-8} \text{ T}$

6) The magnetic force acting on a charged particle :

- a) Changes the magnitude of velocity only .  
b) Changes both magnitude and the direction of velocity .  
c) Changes the direction of velocity only  
d) Doesn't change the direction of velocity

7) In which direction will the electron in Figure be deflected as it enters the constant magnetic field ?

- a) into the page      b) out of the page  
c) upward      d) downward

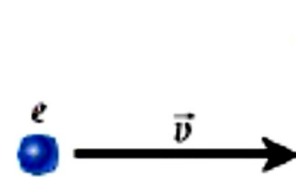

8) An electron is traveling from the northwest toward the southeast in a region of space where the Earth's magnetic field is directed horizontally toward the north. What is the direction of the magnetic force on the electron?

- a) + y      b) - x      c) - z      d) + z

9) A magnetic field is oriented in a certain direction in a horizontal plane . An electron moves in a certain direction in the horizontal plane . For this situation , how many is the possible directions of the magnetic force on the electron ?

- a) 1      b) 2      c) 3      d) infinite number

10) A charged particle is at rest when a magnetic field is suddenly turned on . The field points in the z-direction . What is the direction of the net force acting on the charged particle ?

- a) in the x-direction      b) in the y-direction  
c) in the z-direction      d) The net force is zero.

11) In which direction does a magnetic force act on an electron that is moving in the positive x-direction in a magnetic field pointing in the positive z-direction?

- a) the positive y-direction
- b) the negative x-direction
- c) the negative y-direction
- d) any direction in the xy-plane

12) A charged particle is moving in a constant magnetic field . Which of the following statements concerning the magnetic force exerted on the particle is not true ?

- a) It does not work on the particle .
- b) It may change the velocity of the particle .
- c) It may increase the speed of the particle .
- d) It can act only on the particle while the particle is in motion .

13) A proton is moving in negative y-direction perpendicular to a magnetic field , experiences a force of magnitude F , acting in the negative x-direction.

What is the direction of the magnetic field producing this force ?

- a) + z
- b) - z
- c) + x
- d) + y

**Motion of charged particles in a magnetic Field ( 7 – 3 )**

When a charged particle moves perpendicular to a uniform magnetic field, it takes a circular path as shown in the figure .

**The Reason :**

Because the particle is affected by a magnetic force always perpendicular to its velocity, acting as a centripetal force that causes it to move in a circular path.

The magnetic force is always towards the center , so it is called the centripetal force.

The radius of the particle's path is calculated from the relationship :

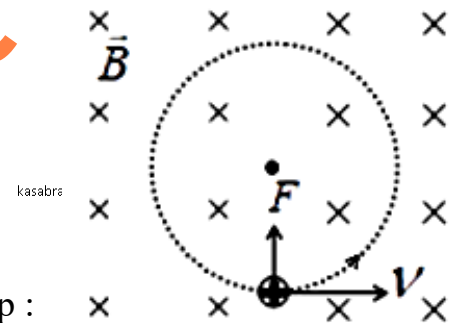

$$F_B = F_C$$

$$|q|vB = \frac{mv^2}{r}$$

$$r = \frac{mv}{|q|B}$$

$$r = \frac{p}{|q|B}$$

m : mass

p : momentum of particle ( p = m v )

If the particle moves parallel to the field, it will not be affected by a magnetic force and will continue to move in a straight line.

If the particle moves not perpendicular to the field it will move in a helical path and its radius will be calculated from :

$$r = \frac{mv \sin \theta}{|q|B}$$

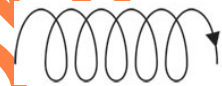

Q9) Determine the direction of particle's rotation in the following :

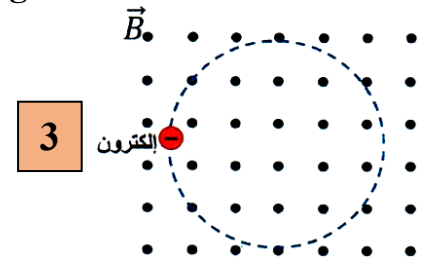
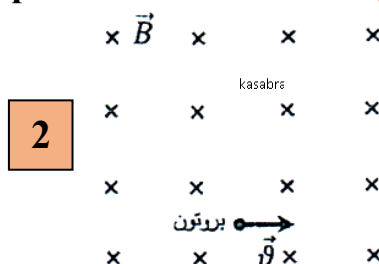
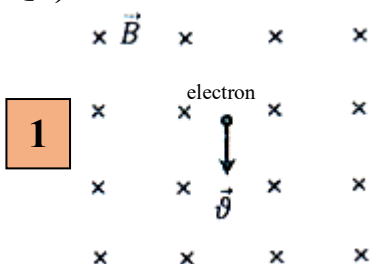

**Q10) A proton in a magnetic field moves counterclockwise on a circle in xy plane, with a magnetic field of  $(0.25 T)$  and a velocity of  $(6.2 \times 10^6 \text{ m/s})$ , considering  $(q_p = 1.6 \times 10^{-19} \text{ C})$ ,  $(m_p = 1.67 \times 10^{-27} \text{ Kg})$**

- 1) Calculate the radius of the proton's circular path .
- 2) Determine the direction of the magnetic field .
- 3) If the magnetic field is doubled to three times what happens to each of the following
  - a) Magnetic force .
  - b) Acceleration of the proton .
  - c) Radius of the proton's path .
  - d) Speed of the proton .

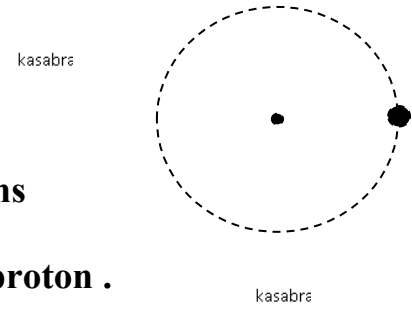

**Q11) A particle with charge of  $(1.6 \times 10^{-19} \text{ C})$  is moving in a circular path of radius  $(2.3 \text{ m})$ , the magnetic field affected has a magnitude of  $(0.5 T)$  :**

- 1) Calculate the momentum of the particle .
- 2) Calculate the kinetic energy of the particle in units of electron volts, consider the mass of the particle is  $(2.5 \times 10^{-25} \text{ Kg})$  .

**Q12) A small, charged ball of mass  $(3.44 \text{ g})$  is moving north with a speed of  $(3.18 \times 10^3 \text{ m/s})$ . If you want the ball to move in a horizontal circular path of radius  $(1.89 \text{ m})$  in a clockwise direction when looking at it from above, considering the magnetic field is  $(0.51 T)$  into the page :**

- 1) Calculate the charge of the ball and determine its type .
- 2) In which direction should the ball be ejected in order to travel in a straight path within the field .
- 3) What will the shape of the path be if the ball's velocity makes an angle  $(40^\circ)$  with the magnetic field direction ?

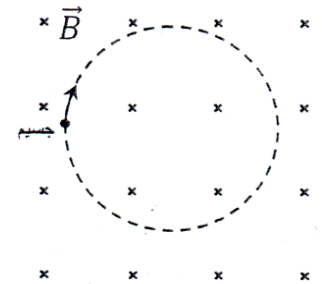

**Q13) The figure shows the paths of two particles (x, y) charged with the same masses when they were projected into the same magnetic field with the same speeds .**

- 1) What is the kind of each charge ?  
Charge of (x) : .....  
Charge of (y) : .....
- 2) Explain why the particle's charge (x) is less than the particle's charge (y) .

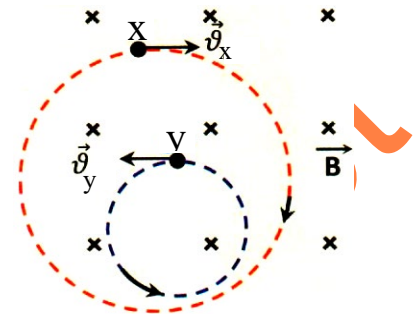

**Q14) An electron with kinetic energy equal to  $(4 \times 10^2 \text{ eV})$  and an electron with kinetic energy equal to  $(2 \times 10^2 \text{ eV})$  are trapped in a uniform magnetic field and move in circular paths . What is the ratio of the radii of their orbits  $(\frac{r_1}{r_2})$ ?**

**Q15) An alpha particle  $(q = +2e, m = 6.64 \times 10^{-27} \text{ Kg})$  is accelerated by a potential difference of  $(2700 \text{ V})$  and moves in a plane perpendicular to a constant magnetic field of magnitude  $(0.34 T)$ , the alpha particle is moving in a circular path . Calculate the radius alpha's path .**

**Q16) An electron with a speed of  $(4 \times 10^5 \text{ m/s})$  enters a uniform magnetic field of magnitude  $(0.04 T)$  at an angle of  $(35^\circ)$  to the magnetic field lines by considering  $(m_e = 9.1 \times 10^{-31} \text{ Kg})$**

- 1) Calculate the radius of the path and determine path's shape .
- 2) How far forward will the electron have moved after a time  $(1 \mu\text{s})$  ?

**Q17) At a certain time an electron crosses the positive y-axis at (60 cm) from the origin with velocity ( $2.0 \times 10^5 \text{ m/s}$ ) in the positive x-direction as in the figure. ( $m_e = 9.1 \times 10^{-31} \text{ Kg}$ )**

**1) Calculate the magnitude and the direction of the magnetic field that will cause the electron to cross the x-axis at (60 cm) from the origin.**

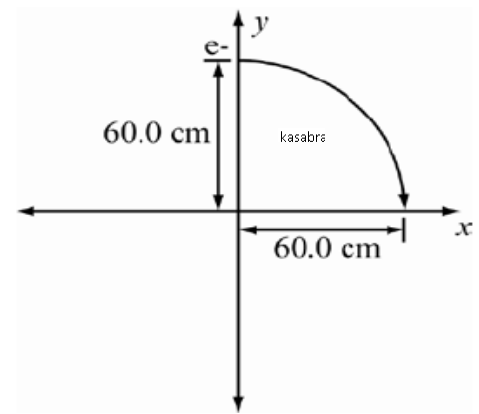

**2) What is work done on the electron during this motion ?**

**Q18) Choose the correct answer in the following**

**1) A positively charged particle entered a uniform magnetic field and moved along the path as shown in the figure, the velocity of the particle when it entered the field was :**

- in the direction of the field .
- perpendicular to the direction of the field .
- in direction opposite to the field .
- in a direction makes a certain angle with the direction of the field .

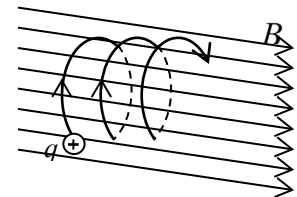

**2) What is the relationship between the magnitude of the path radii of each of the two ions (x , y) when they are ejected at the same velocity perpendicular to the uniform magnetic field lines , as shown in the figure :**

- $\frac{r_x}{r_y} = \frac{1}{1}$
- $\frac{r_x}{r_y} = \frac{1}{4}$
- $\frac{r_x}{r_y} = \frac{4}{1}$
- $r_x \times r_y = 1$

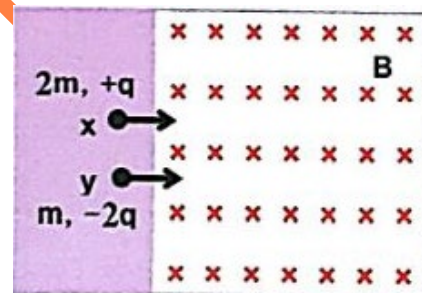

**3) An electron moves in a circular path with radius ( $r$ ) in a constant magnetic field . What is the final radius of the path when the magnetic field is doubled ?**

- $2r$
- $4r$
- $\frac{r}{2}$
- $\frac{r}{4}$

**4) Which of the following relationships represents the magnetic force vector on a charged particle moving in a magnetic field?**

- $\vec{F}_B = q(\vec{v} \times \vec{B})$
- $\vec{F}_B = q(\vec{v} \cdot \vec{B})$
- $\vec{F}_B = q(\vec{B} \cdot \vec{v})$
- $\vec{F}_B = q(\vec{B} \times \vec{v})$

**5) A proton is accelerated from rest by a potential difference of (400V) . The proton enters a uniform magnetic field and follows a circular path of radius (20 cm) . Determine the magnitude of the magnetic field . ( $m_p = 1.67 \times 10^{-27} \text{ Kg}$ )**

- $1.44 \times 10^{-3} \text{ T}$
- $1.44 \text{ T}$
- $1.44 \times 10^{-4} \text{ T}$
- $1.44 \times 10^{-2} \text{ T}$

**6) A proton moving at speed ( $1.1 \times 10^6 \text{ m/s}$ ) enters a region in space where a magnetic field given by  $\vec{B} = (-0.5 \text{ T}) \hat{y}$  . The velocity vector of the proton is at an angle ( $60^\circ$ ) with respect to the positive x-axis , Calculate the radius of proton's path .**

- $1.15 \times 10^{-2} \text{ m}$
- $2.23 \times 10^{-2} \text{ m}$
- $1.99 \times 10^{-2} \text{ m}$
- $4.51 \times 10^{-2} \text{ m}$

في درس (3-7) المواضيع التالية محذوفة وكل ما يتعلق بها من أسئلة في نهاية الوحدة :

Magnetic Force on a Current-Carrying wire (7 - 4)

$$\vec{F}_B = i \vec{L} \times \vec{B}$$

$$F_B = i L B \sin \theta$$

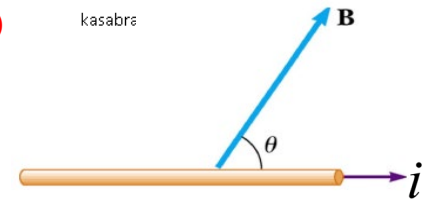

L : Length of the wire

The wire is parallel to the field

$$F_{\min} = 0$$

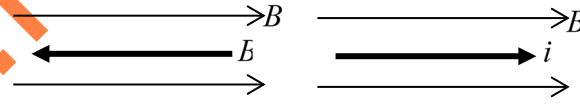

The wire is perpendicular to the field

$$F_{\max} = i L B$$

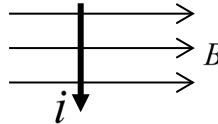

Direction of force by Right hand rule

Thumbs with the current

Fingers with a magnetic field

Out of the right hand is the direction of ( $F_B$ )

The direction of ( $\vec{F}$ ) is always perpendicular to both ( $\vec{B}$ ) and ( $i$ )

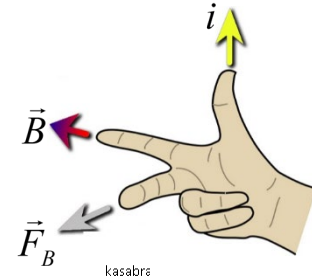

Q19) In the figure shown , determine the direction of the magnetic force on the wire

1

2

3

4

5

Q20) A straight wire of length (0.5m) carries a current of (2 A) placed in a uniform magnetic field of magnitude ( $2 \times 10^{-2} T$ ), as shown in the figure :

1) Calculate the magnitude of the magnetic force on the wire and determine its direction .

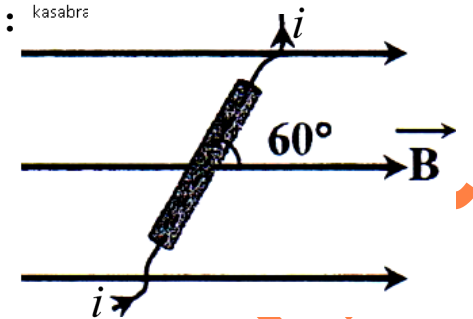

2) How can we place the wire in the field in such a way that there is no magnetic force act on it ?

Q21) A straight wire of length (40cm) and carrying a current of magnitude (6.0 A) is placed in a uniform magnetic field (0.8T) as shown in the figure , if the magnetic force on the wire is (0.96 N) :

- Determine the direction of the magnetic force acting on the wire .
- Calculate the angle ( $\theta$ ) between the wire and the magnetic field's direction .

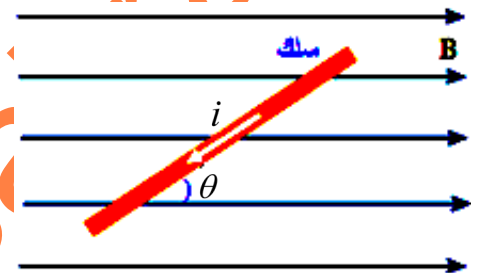

3) If the wire's position is modified to make the magnetic force acting on it as large as possible and in the direction into the page :

- Draw the new position of the wire inside the field .
- Calculate the maximum magnetic of the force on the wire .



**Q22)** A straight wire of length (30 cm) and carrying a current of magnitude (2.0 A) in negative y-direction is placed in a uniform magnetic field given by  $(\vec{B} = 0.40\hat{x} + 0.70\hat{y} + 0.25\hat{z})$ , Calculate the magnitude of the magnetic force on the wire.

**Q23)** A straight wire with a constant current running through it in Earth's magnetic field, at a location where the magnitude is (0.43 G). What is the minimum current that must flow through the wire for a (10 cm) length of it to experience a force of (1.0 N).

**Q24)** A Loudspeaker consist of a voice coil with a diameter of (2.5 cm) and a (100) turns and carrying a current (1.0 mA) is placed in a magnetic field (1.5 T) perpendicular to its coil, calculate the magnetic force exerted by the magnetic field on the loudspeaker's voice coil.

**Q25)** A (12 V) battery is connected to a (3.0 Ω) resistor in a rigid rectangular loop of wire. As shown in the figure, a length ( $\ell = 1.0 m$ ) of wire at the end of the loop extends into a magnetic field of magnitude (5.0 T), directed into the page. What is the net force on the loop?

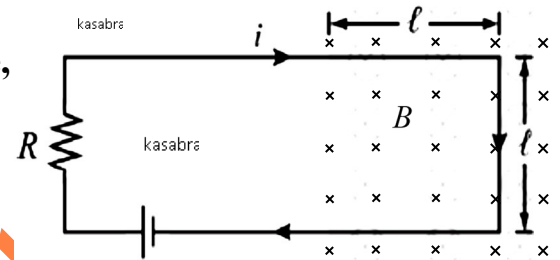

**Q26)** As shown in the figure, a straight conductor can slide without friction on top of two horizontal conducting rails and a distance of (0.2 m) apart, in a vertical magnetic field of (1.0 T). A (20 A) current is maintained through the conductor.

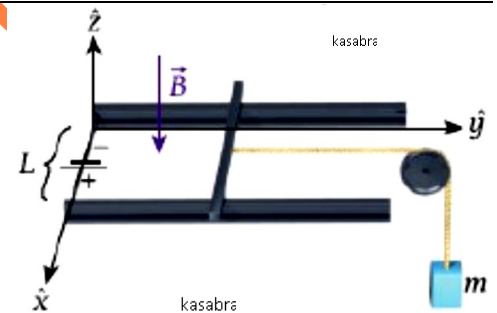

If a string is connected exactly at the center of the conductor and passes over a frictionless pulley, what mass (m) suspended from the string allows the conductor to be at rest and determine the current's direction in the conductor?

**Q27)** Choose the correct answer in the following

1) In the figure, the wire (x, y) is free to move, in which direction you will expect the wire to move when a current pass through it from (x) to (y):

a) To the right    b) To the left    c) upward    d) downward

2) What is the unit that is equivalent to  $(A \cdot m \cdot T)$

a) Volt    b) Joule    c) Ampere    d) Newton

3) What unit is equivalent to  $(Kg \cdot A^{-1} \cdot S^{-2})$

a) Tesla    b) Joule    c) Newton    d) Volt

4) A wire in the plane of page carries a current towards the east and perpendicular to the Earth's magnetic field, what is the direction of the magnetic force on the wire.

a) into the page    b) out of the page    c) North    d) South

5) A wire with an electric current is placed in four different positions in a uniform magnetic field as in the figure shown, which diagram will the magnetic force on the wire be the maximum.

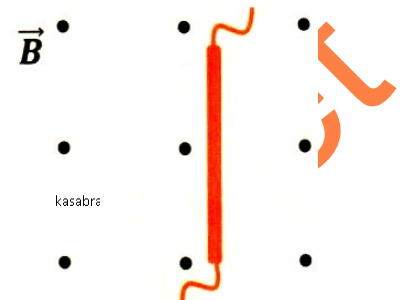
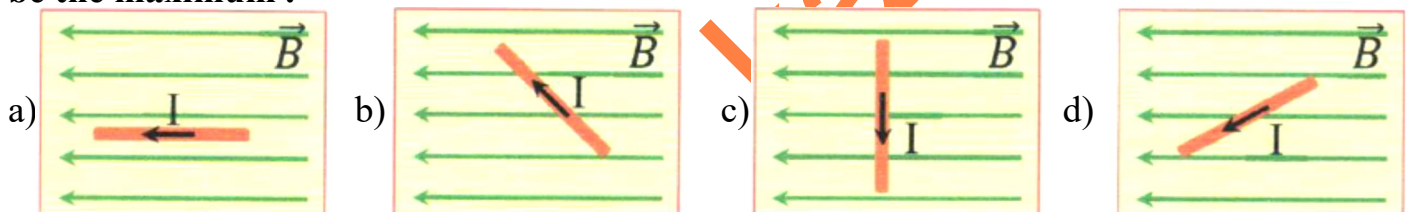

6) In the figure shown, what is the direction of the magnetic field that causes the maximum magnetic force

- positive y-direction
- negative x-direction
- negative y-direction
- positive x-direction

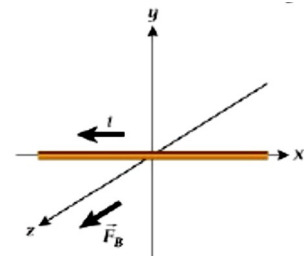

7) A wire is carrying a current in the positive y-direction as shown in the figure, the wire is located in a uniform magnetic field oriented in such a way that the magnetic force on the wire is maximized toward the negative x-direction, what is the direction of magnetic field ?

- negative y-direction
- positive x-direction
- positive z-direction
- negative z-direction

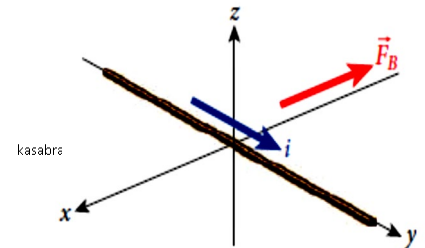

8) In the figure shown, what is the direction of the magnetic force on the wire ?

- positive x-direction
- negative x-direction
- positive z-direction
- negative z-direction

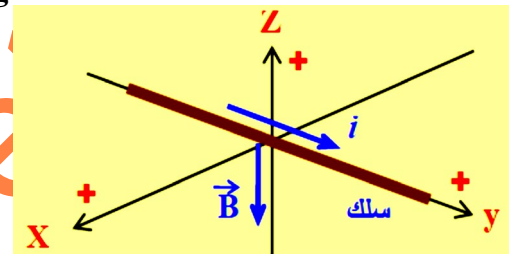

9) A straight wire of length (2.0 m) carries a current of (24 A). It is placed on a horizontal tabletop in a uniform horizontal magnetic field. The wire makes an angle of (30°) with the magnetic field lines. If the magnitude of the force on the wire is (0.5 N) what is the magnitude of the magnetic field ?

- $2.1 \times 10^{-2} T$
- $4.2 \times 10^{-2} T$
- $1.1 \times 10^{-2} T$
- $3.2 \times 10^{-2} T$

10) A straight wire of length (10 cm) carries a current of (3.41 A) is placed horizontally and makes an angle of (10°) with positive x-direction, if a magnetic field of (0.22 T) in positive y-direction acting on the wire. What is the magnitude and the direction of that magnetic force ?

- $1.30 \times 10^{-2} N (+z)$
- $1.30 \times 10^{-2} N (-z)$
- $7.39 \times 10^{-2} N (+z)$
- $7.39 \times 10^{-2} N (-z)$

### Torque on a Current-Carrying Loop $\tau$ (7-5)

$$\tau = iAB \sin \theta$$

A : Area of the loop

unit of  $\tau$  :  $N.m$

$\theta$  : angle between  $\vec{B}$  and unit vector  $\hat{n}$  (normal to the plane of loop)

\* In case of coil with several (N) turns :

$$\tau = NiAB \sin \theta$$

- Direction of  $\hat{n}$  : **Right hand rule** (2)

Fingers bend with current .

The thumb with  $\hat{n}$  as shown in the figure .

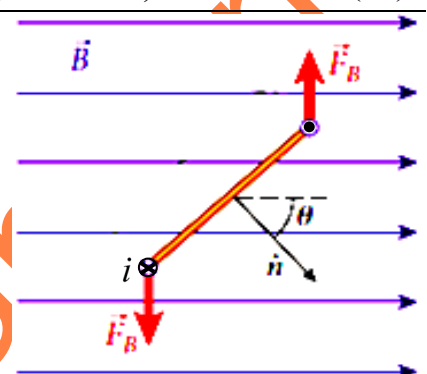

$(\vec{B})$  is parallel to the plane of loop : ( $\theta = 90^\circ$  between  $\vec{B}$  and  $\hat{n}$ )  $\tau_{\max} = iAB$

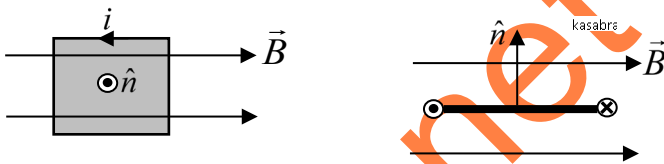

$(\vec{B})$  is normal to the plane of loop : ( $\theta = 0$  or  $180^\circ$  between  $\vec{B}$  and  $\hat{n}$ )  $\tau_{\min} = 0$

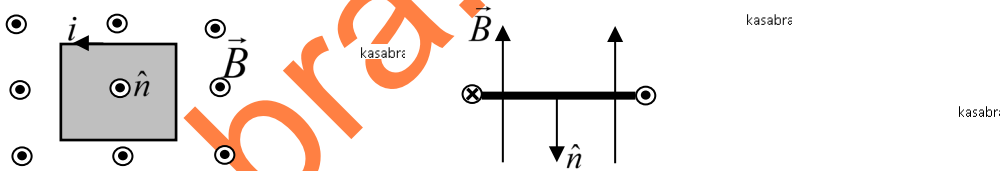

**Q28)** A wire loop with area of  $(0.05 \text{ m}^2)$  is placed in a uniform magnetic field  $(0.4 \text{ T})$ , if the current in the loop is  $(10 \text{ A})$ , Calculate the magnitude of the torque in the following cases :

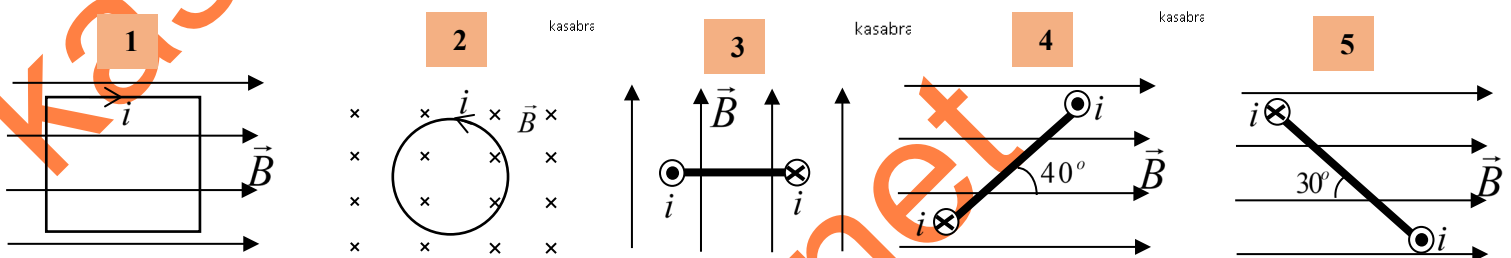

**Q29)** A rectangular coil with  $(20)$  windings carry a current of  $(2.0 \text{ mA})$  flowing in the counterclockwise direction. It has two sides that are parallel to the y-axis and have length  $(8.0 \text{ cm})$  and two sides that are parallel to the x-axis and have length  $(6.0 \text{ cm})$ . A uniform magnetic field of  $(50 \mu\text{T})$  acts in the positive x-direction. Calculate the magnitude of the torque must be applied to the loop to hold it steady?

**Q30)** Twenty loops of wire are tightly wound around pencil that has a diameter of  $(6.0 \text{ mm})$ . The pencil is then placed in a uniform  $(5.0 \text{ T})$  magnetic field, as shown in the figure. If a  $(3.0 \text{ A})$  current is present in the coil of wire. What is the magnitude of the torque on the pencil?

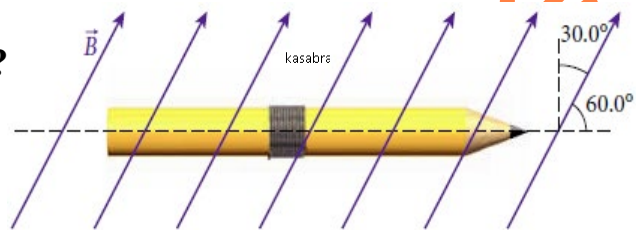

**Q31)** A circular coil with a radius of  $(10 \text{ cm})$  has  $(100)$  turns of wire and carries a current  $(100 \text{ mA})$ . It is free to rotate in a region with a constant horizontal magnetic field given by  $\vec{B} = (0.01 \text{ T}) \hat{x}$ . If the unit normal vector to the plane of the coil makes an angle of  $(30^\circ)$  with the horizontal :

1) Calculate the magnitude of the torque acting on the coil?

2) If the radius of the loop is decreased to  $(5.0 \text{ cm})$ , what should the number of turns be for the torque to remain unchanged, assume that  $(i, B, \theta)$  stay the same.

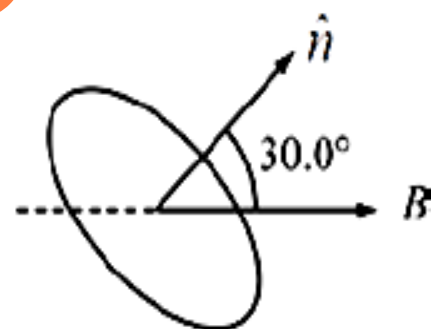

**Q32) A coil of wire consisting of (40) loops with width (16cm) and height (30cm) is placed in a constant magnetic field given by  $[\vec{B} = 0.065\hat{x} + 0.25\hat{z}]$**

**and a current of (0.2A) runs through the wire :**

**1) Calculate the magnitude of the torque on the coil .**

**2) Calculate the magnitude of the force on the segment (ab) of the coil .**

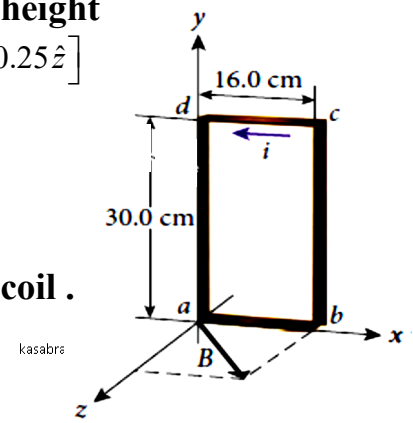

**Q33) Choose the correct answer in the following :**

**1) A coil is composed of circular loops of radius (5.13 cm) and has (47) windings . A current (1.27 A) flows through the coil , the coil is placed in a magnetic field of magnitude (0.911T)**

**What is the maximum torque on the coil due to the magnetic field?**

- a) 0.148 N.m
- b) 0.211 N.m
- c) 0.350 N.m
- d) 0.450 N.m

**2) The top view of a current loop in a constant magnetic field as shown in the figure , the torque on the loop will cause it to rotate :**

- a) clockwise
- b) counterclockwise
- c) not rotate
- d) not at all

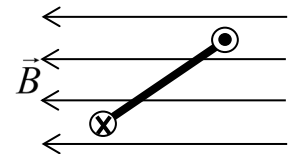

درس (6 - 7) و درس (7 - 7) غير مطلوبين .

## Applications of the magnetic force acting on the wire

### The Electric motor

A device that converts electrical energy into kinetic, such as a washing machine, fan.....

The components :

- 1) A coil
- 2) A magnet
- 3) A commutator

The **commutator** consists of a split ring .

The function of the commutator is to reverse the direction of the current in the loop every half periodic time until the rotation continues in the same direction .

(The direction of current changes two times for every one rotation of the loop)

**Working principle :**

The two ends of the coil perpendicular to the field are affected by two forces of equal magnitude and opposite directions forming a torque that rotate the coil around an axis .

